

## Bauder Bitumen Compact Vertical Outlet DN 100

V6 29.10.2024

### Product description

A thermally insulated cast polyurethane rainwater outlet with vertical spigot giving thermal continuity. The outlet comes with a pre-attached bituminous flange to ensure waterproofing integrity between the outlet and membranes. The BRE Certified (report no. HPR357-303748) high thermal value of the rigid foam body prevents condensation from forming on the underside of the outlet body.

### Application fields

Outlet has a flow rate of 6.1 litres/sec based upon requirements of BS EN 12056:3:2000. For use with Bauder bituminous waterproofing membranes when connecting to conventional gravity drainage systems. The product is designed to be used in warm, cold, and inverted roof scenarios. The spigot is designed to fit a standard 110mm pipework (see pipework connectivity information below). Where a warm roof system is specified, a separate extension piece will need to be ordered to maintain thermal integrity. This is available with a spigot length that can range from 60mm to 220mm according to the insulation thickness specified. A separate 60mm thick extension unit housing can also be ordered to accommodate the extension piece to save having to cut insulation on site to suit.

### Article Number

Compact Outlet body for warm, cold, and inverted roofs	GB60262100
Compact Extension Unit for warm roofs only	GB60263120
Compact Extension Unit Housing for warm roofs only	GB60266010
Reinforcement plate for metal decks only	GB60266250

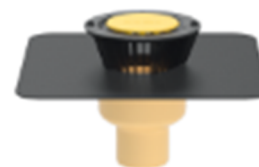

Characteristic - Compact Outlet	Unit	Value
Length of outlet including spigot	mm	210
Length of outlet	mm	135
Length of spigot	mm	75
Width of outlet opening	mm	146
Width of spigot (external)	mm	110
Width of spigot opening	mm	100
Width of outlet body	mm	250
Width of outlet body and lugs	mm	320
Width of bituminous flange	mm	495
Length of bituminous flange	mm	495
Flange surface finish (bottom)	-	fleece
Flange surface finish (top)	-	bitumen with a polyethylene film
Weight	kg	2.1
Flow rate performance	litres/sec	6.1*

\*Flow rate performance data using a 35mm head of water (including leaf grille), based upon requirements of BS EN 12056:3:2000. Further flow rate performance data can be obtained within this document. For bespoke drainage calculation performance data, please contact Bauder Limited.

Characteristic - Compact Outlet Extension Unit	Unit	Value
Length of extension unit	mm	255 (can be used for insulation depths 60 to 220mm)
Width of extension unit opening	mm	146
Width of extension unit spigot (external)	mm	131
Width of extension unit spigot opening	mm	122
Width of extension unit body	mm	320
Width of bituminous flange	mm	495
Length of bituminous flange	mm	495
Flange surface finish (bottom)	-	fleece
Flange surface finish (top)	-	bitumen with a polyethylene film
Weight	kg	2.2

# Technical data sheet

<b>Flow rate performance</b>	litres/sec	6.1*
*Flow rate performance data using a 35mm head of water (including leaf grille), based upon requirements of BS EN 12056:3:2000. Further flow rate performance data can be obtained within this document. For bespoke drainage calculation performance data, please contact Bauder Limited. The Compact Outlet Extension Unit to be used in conjunction with the Compact Outlet for warm roof build-ups only.		
<b>Characteristic - Compact Outlet Extension Unit Housing</b>	<b>Unit</b>	<b>Value</b>
<b>Length of extension unit housing</b>	mm	500
<b>Width of extension unit housing</b>	mm	500
<b>Depth extension unit housing</b>	mm	60
<b>Thermal Conductivity</b>	W/mK	0.025
<b>Weight</b>	kg	1.84
The Compact Extension Unit Housing can be purchased separately for use with the Compact Outlet Extension Unit.		

## Storage guidance

Store under cover. The product should be stored dry, protected against weathering, and must not be exposed to temperatures exceeding 35°C. The products must not be exposed to a direct naked flame or other ignition sources, or to solvents or other chemicals. Ensure the product(s) are clear of buildings and any other storage areas. Where there are storage containers on site, these may be suitable for storing products. Outlet bituminous flanges that have become wet must be allowed to fully dry out naturally before use.

The leaf grille will be supplied with the outlet itself. For warm roofs, an extension unit will be required and the leaf grille from the outlet will need to be removed, set aside, and placed into the extension unit once installed. Please see detail drawing below.

## Packaging material

The product will be delivered in a carboard box which is readily recyclable.

## Handling/PPE

All persons using the product should be fully aware of the manual handling methods as roofing materials are heavy and can cause serious injury. When using the product, installers should be provided with, and wear, suitable personal protective equipment.

## Disposal guidance

Disposing of any waste material must be carried out in accordance with national regulations.

## Re-use options of product

Please refer to EPD stated below in Certification and environmental information.

## Further information/ documents

Current documents such as brochures, installation guides, etc. can be found by visiting [www.bauder.co.uk](http://www.bauder.co.uk)

## Certification and environmental information

**ISO 9001:2015 Quality Management Certificates EN1271 (UK)**

**ISO 14001:2015 Environmental Management Certificates A10552 (UK)**

**Environmental Product Declaration: EPD-Kiwa-EE-181397-EN**

## Dimensions:

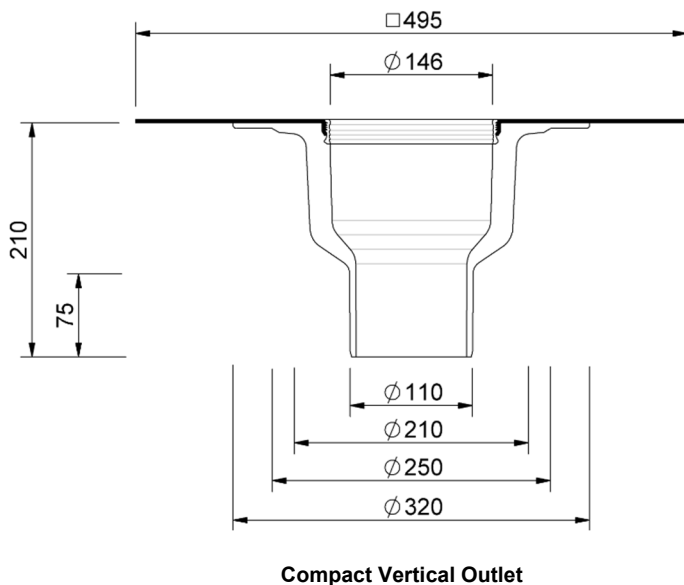

**Compact Vertical Outlet**

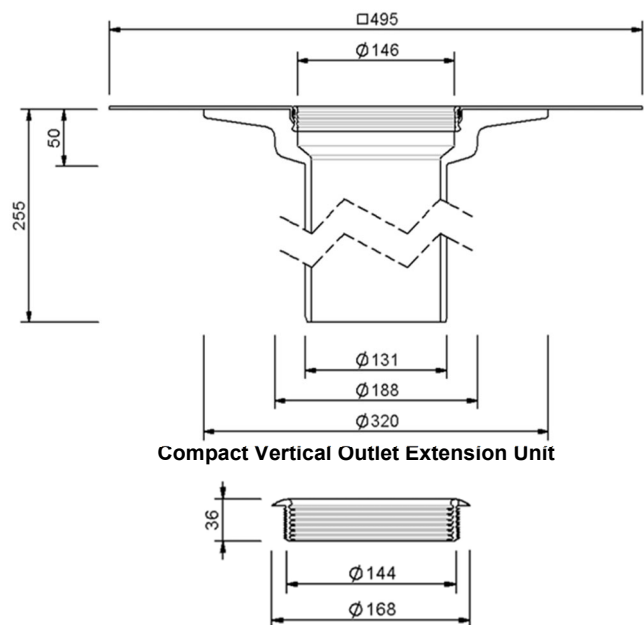

**Compact Vertical Outlet Extension Unit**

**Webbed Insertion Flange**

# Technical data sheet

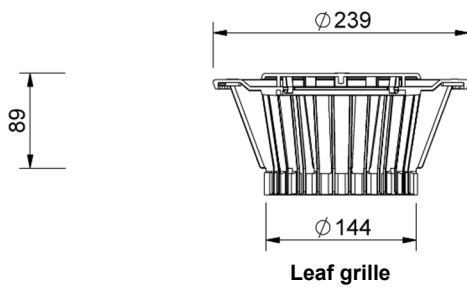

Leaf grille



Compact Extension Unit Housing

Pre-formed to aid installation of the Compact Outlet Extension Unit

Dimensions 500 x 500 x 60mm

Thermal conductivity – Lambda value 0.025 W/mK

**Installation Guidance and data:** Please refer to the Bauder Installation Guide and project specification for guidance.

**Fixing:** The outlet is to be secured through the rim to the structural deck by a minimum of four fasteners appropriate to obtain an adequate attachment to the deck substrate material. Some deck structures require preparatory works before the outlets can be installed:

- **Concrete decks** – the opening for the outlet to be either pre-cast or core-drilled so that the outlet can be installed at the same time as the air and vapour control layer. Provision for a 250 mm dia. opening is required.
- **Profiled metal decks** – these also require a 250 mm dia. Opening cut into the decking, but in addition will require a 600 x 600 x 1.25 mm galvanised steel reinforcing plate secured to the deck before the outlet can be installed. This item has a pre-cut 250 mm dia. hole and is available from Bauder.

**Pipe connection:** Bauder Compact Vertical Outlets are suitable for connection to:

- uPVC "O" ring socketed soil grade pipe to BS 4514: 1983
- Socketed and socket-less cast-iron pipework to BS 416:1973 and EN 887. Socketed pipework will require cold caulking or PVC to cast iron adaptors. Socket-less pipework can be connection using an appropriate SML mechanical coupling.
- HDPE pipework with appropriate SML mechanical coupling

**Connectivity to below deck drainage pipework to be the responsibility of the plumbing contractor/drainage engineer.**

**Compact Outlet Material:** Cast polyurethane body with integral bituminous connection flange.

- **Product size/ reference:**

Bauder Compact Vertical Outlet DN 100, 6.1 litres/sec. flow rate, with vertical spigot designed to connect to standard 110mm pipework.

**Flow rate:** (Based upon vertical pipework and a 35 mm head of water pressure – according to BS EN 12056:3:2000).

- **Type of grate/ fittings:** supplied with a polyamide dome leaf grille. To be set aside for warm roofs and placed into the extension unit upon completion.

- **Alternative:** Bauder Locking Leaf Guard Long Leg: Additional component where higher durability or security is required.

**Bauder Compact Extension Unit - Warm roofs only:** The Bauder Extension Unit is suitable for use with Insulation thicknesses between 60 and 220mm. This will be supplied with a webbed insertion flange which needs to fit tightly into the outlet bowl prior to the extension unit being pushed through, to create a watertight seal. If the insulation is below 60mm in thickness, a timber frame must be built to accommodate the outlet.

**Extension Unit Housing** – Polyurethane housing board 500 x 500 x 60mm with pre-molded opening to receive the Bauder Compact Extension Unit. Thermal Conductivity 0.025 W/mK. Compressive Strength 200 kPa and a Density of 50 kg/m<sup>3</sup>. When the outlet is used as part of a warm roof build-up and the insulation thickness exceeds 60 mm, an additional piece of insulation must be used beneath the extension unit housing, please see alternative detail below.

## Warm Roof Details:

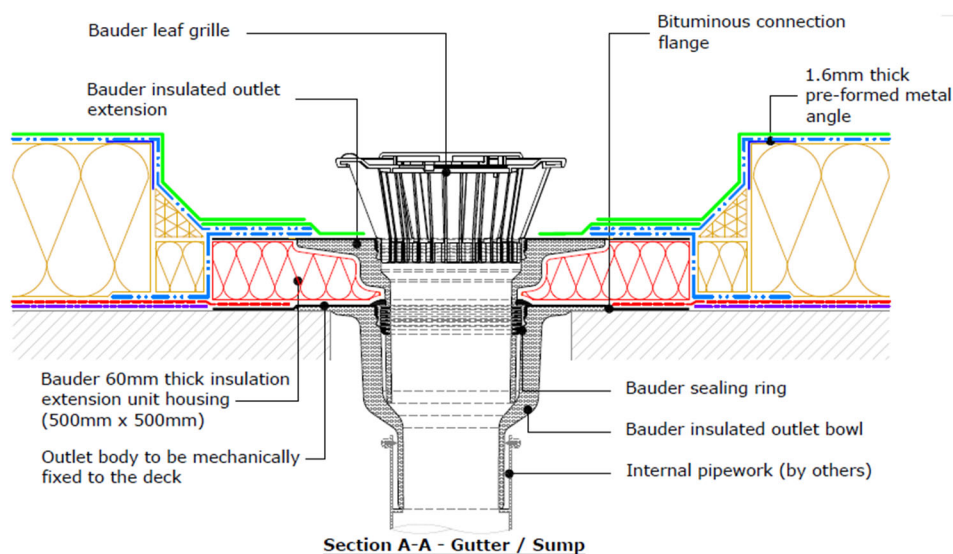

# Technical data sheet

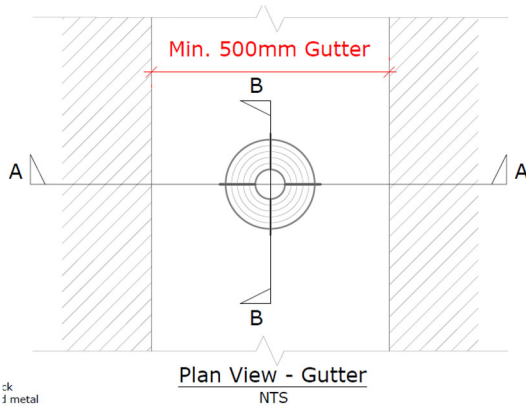

## Alternative Detail

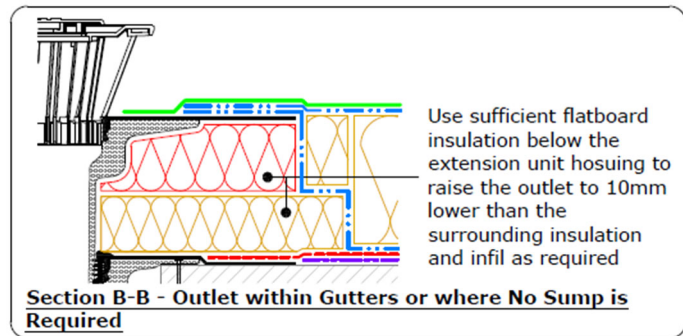

### Cold and Inverted roof detail:

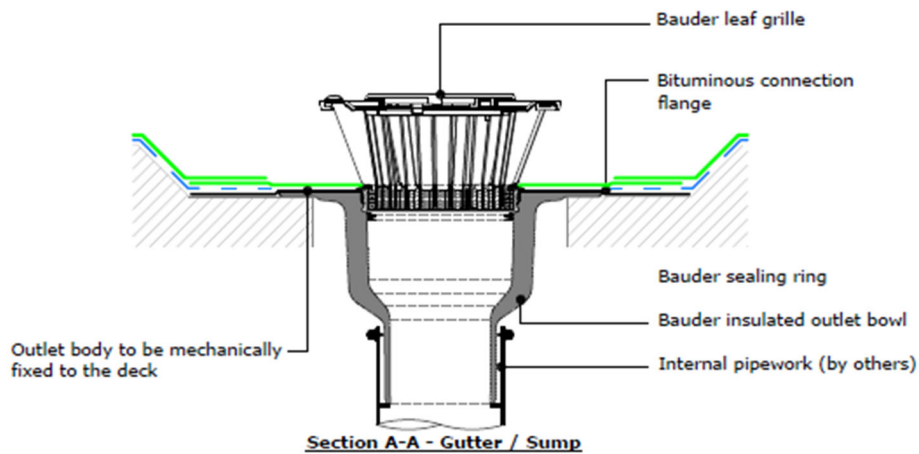

### Drainage performance of the Compact Vertical Outlet:

The figures below are based upon the requirements of BS EN 12056: 3: 2000 and performances are given within 1/3 rainwater pipe capacity limits as required by BS EN 12056.

Flow rates are typically taken using a 35 mm head of water (including leaf grille), which for the Compact Vertical Outlet gives a flow rate performance of 6.1 litres/sec.

		HEAD OF WATER (mm)												
Size	5	10	15	20	25	30	35	40	45	50	55	60	65	
100	0.6	1.5	2.3	3.3	4.3	5.2	6.1	7.3	8.5	9.4	10.3	11.0	11.7	

### When designing a rainwater scheme, the following considerations should apply:

Always make provision for an additional back-up outlet to ensure that the roof will continue to drain in the event of a blockage, even if a single outlet is deemed to have sufficient flow to drain the area concerned.

Allow a safety factor of 10% above the published maximum outlet capacity to take account of greater than designed storm intensities.

Check that all outlets are correctly installed before completion or handover.

Check that all pipe connections are secure and that the leaf grilles are fitted.

All rainwater outlets should be inspected twice yearly for blockages and to clean out the outlets and remove any debris or leaf litter as part of the routine maintenance schedule.

**Safety Data Sheets are designed to provide the necessary information to recipients of substances and mixtures in the EU & UK. This product is classed as an article; therefore, this product does not have a requirement for a Safety Data Sheet.**